

# RTA

Rouleau tasse avant

FABRICATION  
FRANÇAISE

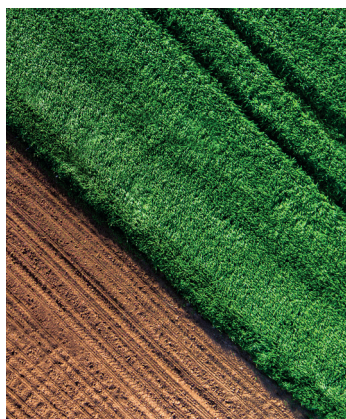

**QUIVOGNE**



# RTA

## Rouleau tasse avant

Le RTA est la solution optimale pour retasser le sol allégé par le labour et briser les mottes.

Son poids important assure un travail efficace et la répartition homogène promet un travail régulier.

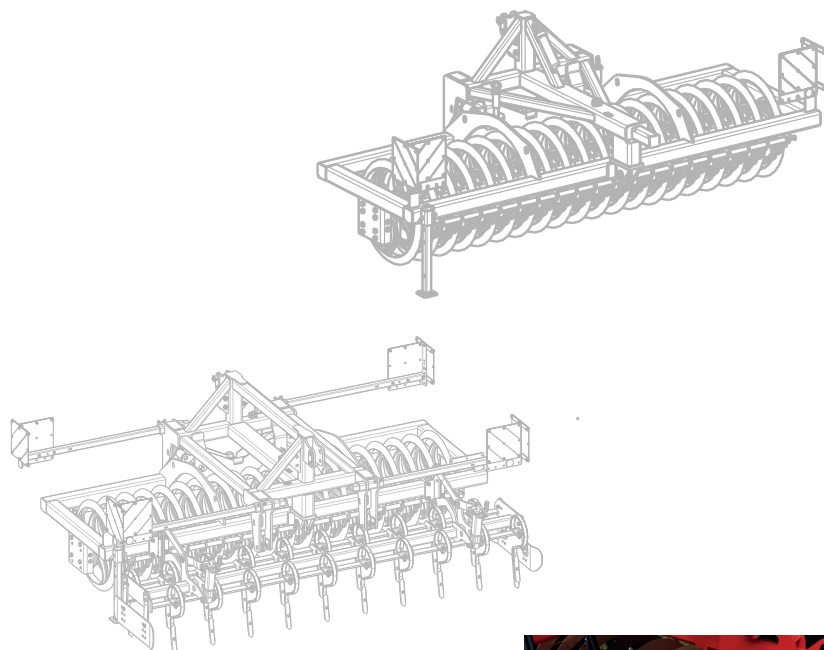

### Les options

- + Planche niveleuse
- + Socs fourchette
- + 2 rangées de dents droites 32x12 ou dents 32x10, 45x12
- + Déflecteur anti-projections
- + Attelage poussé tiré directionnel avec blocage



### Les points forts

- + Chaîne entre anneaux limite le bourrage des fontes
- + L'angle de la fonte permet un bon découpage des mottes
- + Utilisation combinée



## Les caractéristiques techniques

Modèles	Rigide				Repliable				
	150	300	350	400	350	400	460	500	600
Largeur de travail (m)	1,50	3,00	3,30	4,00	3,50	4,00	4,60	5,00	6,00
Largeur de transport (m)	1,70	3,20	3,50	4,20	2,50	2,50	2,50	2,50	2,50
Poids (kg)	840	1350	1485	1620	1570	1825	2100	2438	3050
Poids / anneau (kg)	84	67,5	64	60	68	68	68	72	76
Châssis	Bipoutre 100 x 100 mm								
Attelage	3 points en chape poussé directionnel cat. 2								
Repliage	Par 2 vérins avec verrouillage hydraulique et mécanique								
Arbres	Ø70 mm								
Paliers	60 mm, sans entretien, graissés à vie								
Fonte	Anneaux Ø700mm à branches incurvées, angle 45°								
Distances entre anneaux	150 mm								
Equipement hydraulique requis	1 DE (si modèle repliable)								
Signalisation	De série								

Largeur de travail  
**1,50 à 6 m**



Largeur de transport  
**1,70 à 4,20 m**



Puissance recommandée  
**15 à 120 cv**





# Nous sommes à votre écoute

NOUS CONTACTER

Z.I. des etrapeux 70500 JUSSEY

03 84 68 04 00

contact@quivogne.fr

 @QuivogneFrance

 @Quivogne\_France

 @quivognefrance

 @Quivognefr



## Votre distributeur Quivogne



Quivogne, spécialiste du travail du sol

